



Description

The valves with thermostatic option and presetting are used to slice the delivery water flow rate in a radiator. When the special worksite protection handwheel is fully closed, it is possible to exceed static pressure values of 10 bar with the system disabled.

In any case, it is advised to connect the heating elements before carrying out the pressurised seal tests on the system.

Versions and codes

All versions are interchangeable with TG-series body valves

Series	Product code	Connections	Type
R401PTG	R401PX232	3/8" x 3/8"	Angle
	R401PX233	1/2" x 1/2"	
	R401PX234	3/4" x 3/4"	
R402PTG	R402PX232	3/8" x 3/8"	Straight
	R402PX233	1/2" x 1/2"	
	R402PX234	3/4" x 3/4"	
R403PTG	R403PX252	3/8" x 3/8" (LEFT)	Double angle
	R403PX254	1/2" x 1/2" (LEFT)	
	R403PX262	3/8" x 3/8" (RIGHT)	
	R403PX264	1/2" x 1/2" (RIGHT)	
	R403PX224	1/2" x 18 mm (LEFT)	
R411PTG	R411PX232	3/8" x 16 mm	Angle
	R411PX233	1/2" x 16 mm	
R412PTG	R412PX232	3/8" x 16 mm	Straight
	R412PX233	1/2" x 16 mm	
R415PTG	R415PX242	1/2" x 16 mm	Reverse angle

LEFT version: frontal thermostatic head connection and supply from below; valve to the left of the radiator.

RIGHT version: frontal thermostatic head connection and supply from below; valve to the right of the radiator.

Spare parts

- **P12AX006:** spare parts kit (bonnet, numbered ring, regulation key, instruction) for PTG series valves.

Technical data

- Temperature range: 5÷110 °C
- Max. working pressure: 16 bar
(with thermostatic head or thermo-electric actuator: 10 bar)
- Maximum differential pressure: 1,4 bar

Losses of Pressure

The diagrams show the values of the loss of pressure in straight and angled valves with thermostatic heads $\Delta t = 2\text{ }^{\circ}\text{C}$.

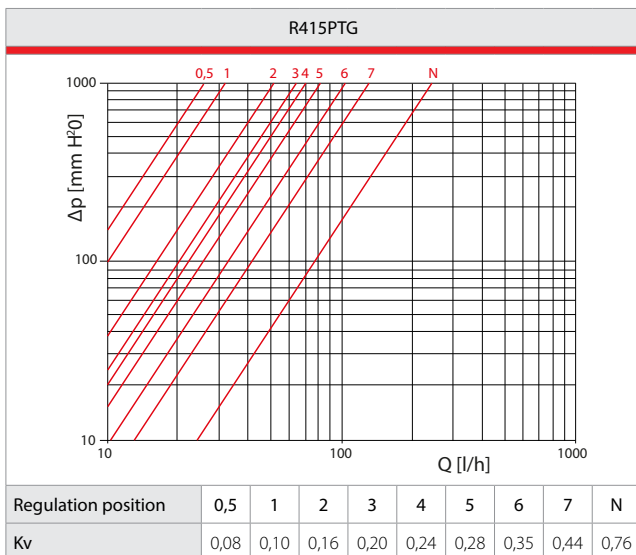
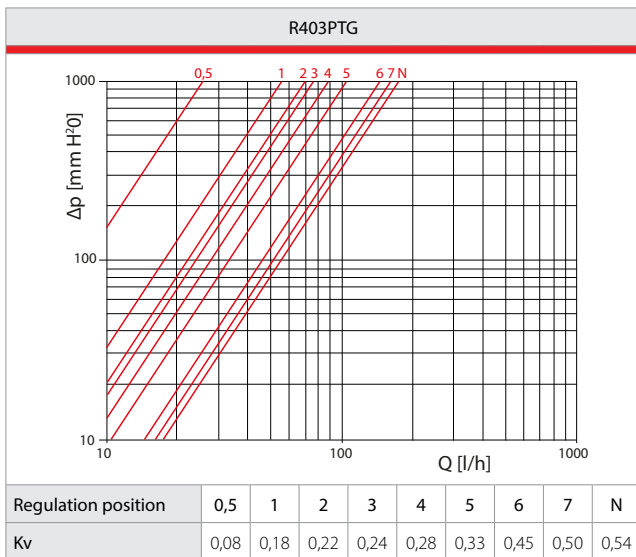
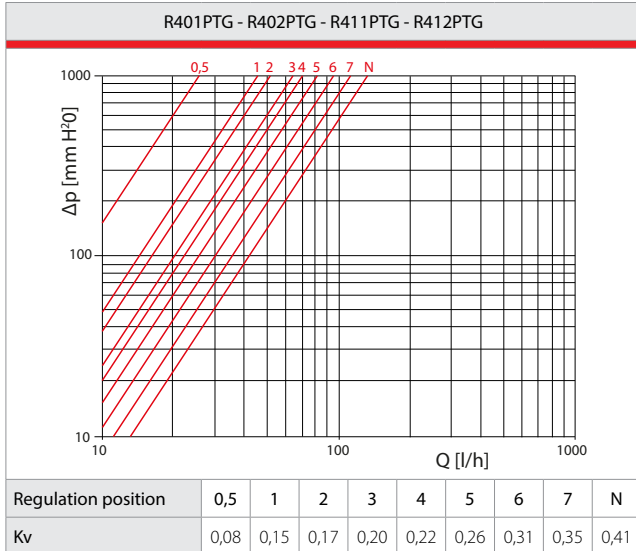

Valve presetting

PTG valves are equipped with a special bonnet (P12AX006) which determines a specific flow section based on the position set, thus generating the desired pressure losses within the hydraulic circuit.

These valves can be pre-set to efficiently balance the circuit.

By combining them with radiator thermostatic heads and chronothermostats they offer great energy saving.

The bonnet has a numbered bush: position 0,5 (single notch) - 1 - 2 - 3 - 4 - 5 - 6 - 7 - N (fully open).

To make the presetting, proceed as follows:



Note.
To adjust the flow rate of the valve, use the R73PY010 spanner.

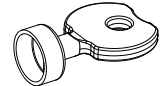

- 1 Remove the red worksite protection using a screwdriver. The stem "B" is positioned on N (fully open).

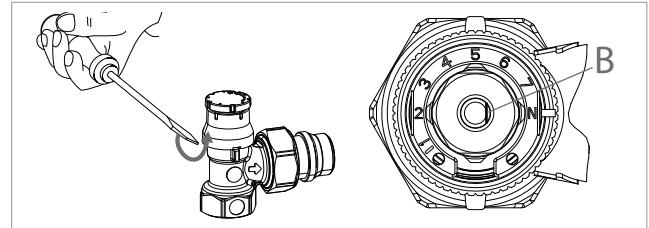

- 2 Set the wrench R73PY010 on the bonnet stem, fitting it in the only position allowed (letter "N" facing the reference "A" on the valve body).

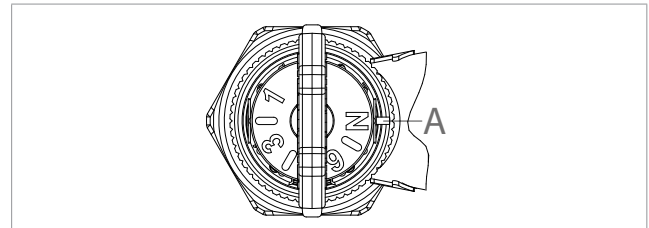

- 3 Turn the bonnet stem using the wrench R73PY010. Move the desired pre-setting number, marked on the wrench, to reference "A" on the valve body.

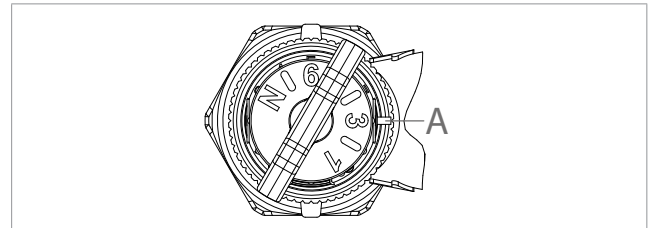

- 4 Remove the wrench R73PY010, the stem "B" will be on the desired pre-setting position, marked by the number on the valve ring.
- Adjustment positions 0,5 (single notch) - 1 - 2 - 3 - 4 - 5 - 6 - 7 - N (fully open).

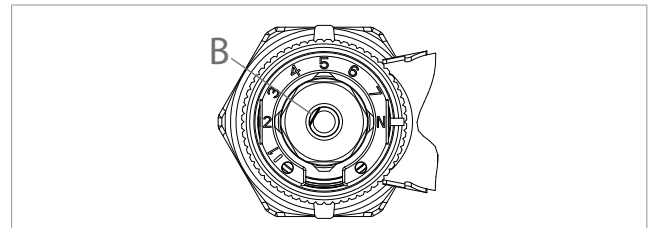

Replacement of P12AX006 bonnet



Warning.

With thermostatic head installed on the valve body, to avoid excessive loads on the seal gasket of the thermostatic bonnet (with the resulting risk of jamming and locking) during the summer, it is recommended to place the handwheel of the thermostatic head in the fully open position, marked by the symbol .



In case of malfunction of the bonnet (P12AX006) is possible to replace it, using the appropriate key R400.

To replace the bonnet, proceed as follows:

- ① Remove the *A* numbered ring using pliers for elastic rings (seeger).



- ② Move the "B" stem of the R400 Allen key about half the way back. Fit the "C" plastic threaded ring connecting it to the valve body pins. Screw the R400 Allen key on the ring nut and install the valve bonnet with the R400 stem, fitting it in correct position.

i Refer to the R400 Allen key instructions.

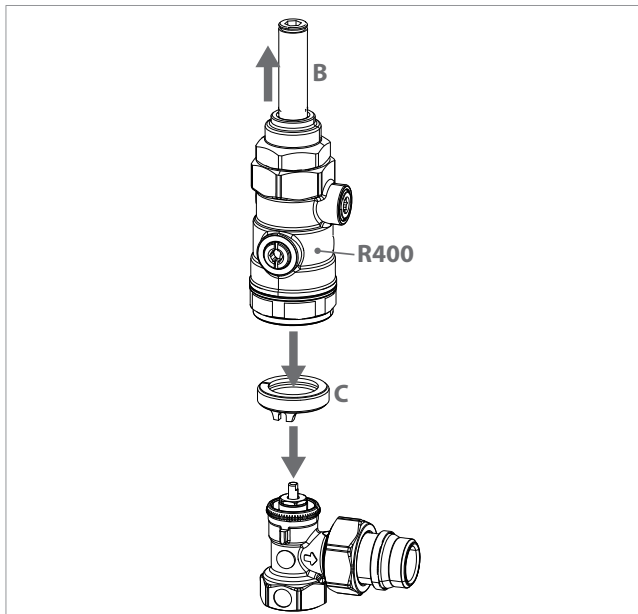

- ③ Unscrew the valve bonnet by turning the R400 Allen key with a 6 mm Allen spanner. Push the stem slightly while performing this step to prevent the bonnet from detaching.

i Refer to the R400 Allen key instructions.

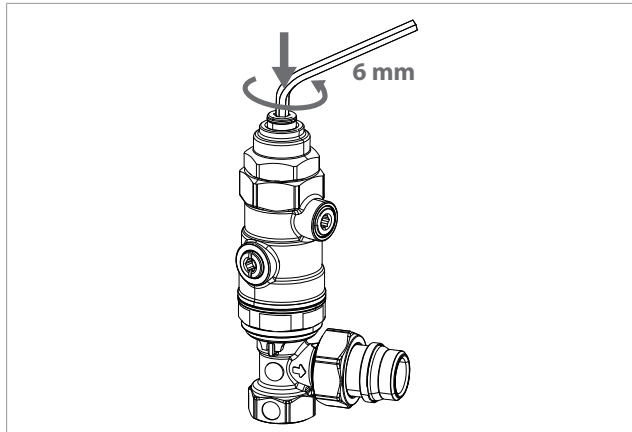

- ④ Tighten the "D" ball valve using a 5 mm Allen spanner, purge the water from the "E" drain and remove the R400 Allen key stem together with the bonnet to be replaced.

i Refer to the R400 Allen key instructions.

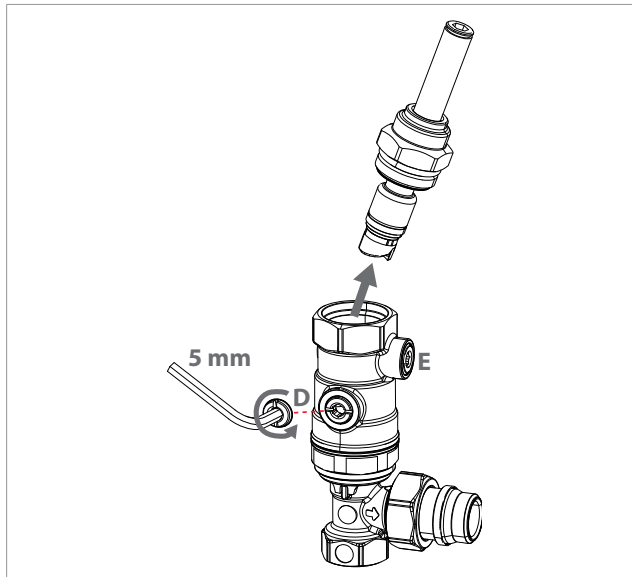

- ⑤ Remove the P12AX006 bonnet and reassemble it inside the valve in reverse order.

Once completed this step, reassemble the numbered ring on the valve paying attention to the position of the numbers: the letter "N" must face the radiator. Now is possible to make the new presetting as described in the paragraph "Valve presetting".

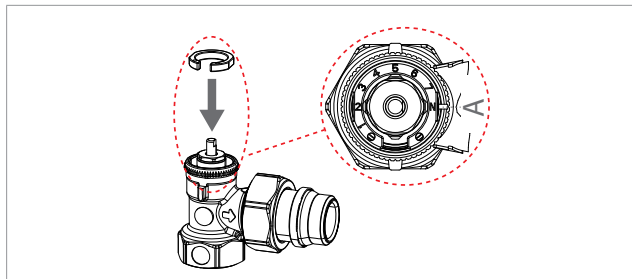



Dimensions

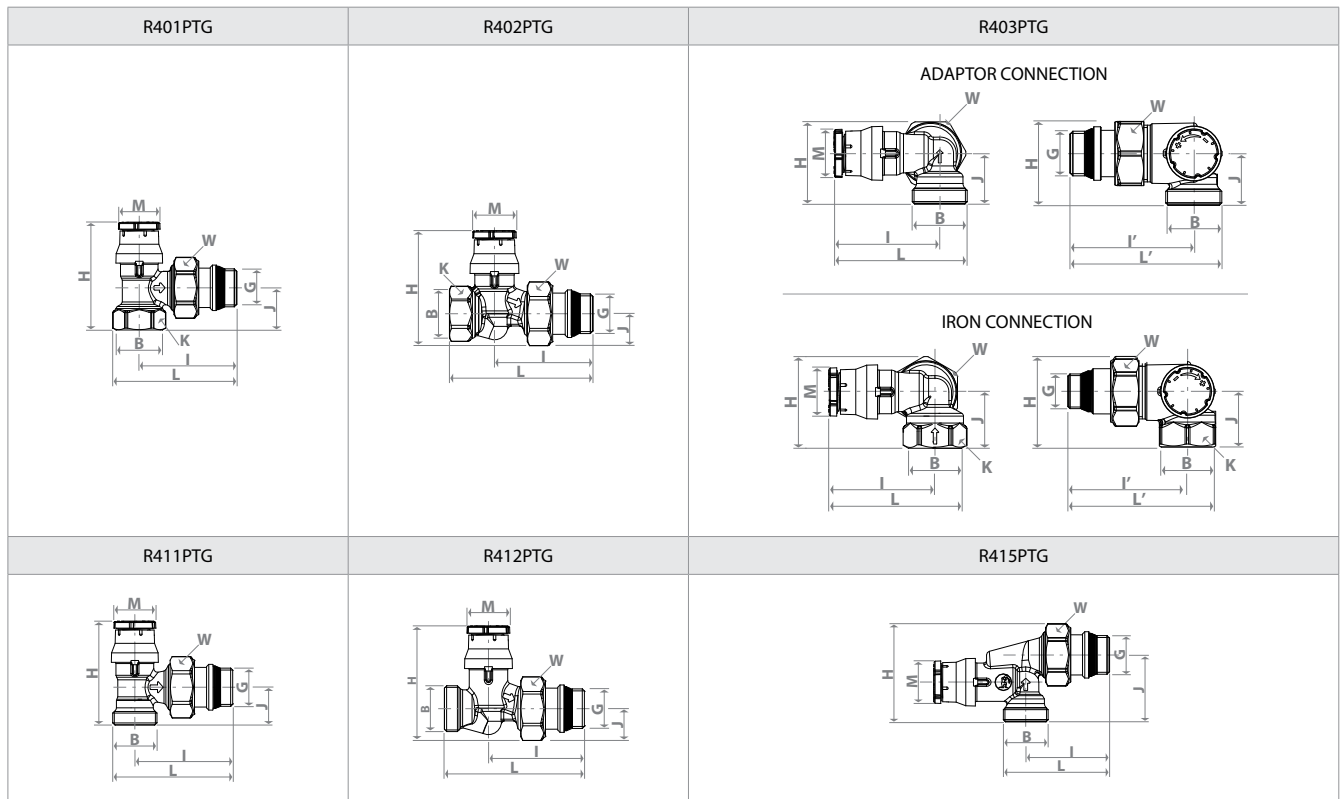

Connection	Product code	GxB	H [mm]	I [mm]	I' [mm]	J [mm]	K [mm]	L [mm]	L' [mm]	M [mm]	W [mm]
Iron pipe	R401PX232	3/8" x 3/8"	55	51	-	20	22	64	-	23	27
	R401PX233	1/2" x 1/2"	59	53	-	23	27	68	-	23	30
	R401PX234	3/4" x 3/4"	61	61	-	25	32	79	-	23	38
	R402PX232	3/8" x 3/8"	58	54	-	15	22	76	-	23	27
	R402PX233	1/2" x 1/2"	60	55	-	17	27	82	-	23	30
	R402PX234	3/4" x 3/4"	65	56	-	21	32	82	-	23	38
	R403PX252	3/8" x 3/8" (LEFT)	43	50	57	27	27	65	71	23	30
	R403PX254	1/2" x 1/2" (LEFT)	43	50	57	27	27	65	71	23	30
	R403PX262	3/8" x 3/8" (RIGHT)	43	50	57	27	27	65	71	23	30
	R403PX264	1/2" x 1/2" (RIGHT)	43	50	57	27	27	65	71	23	30
Adaptor for copper, plastic, multilayer pipe	R411PX232	3/8" x 16 mm	57	53	-	21	-	66	-	23	30
	R411PX233	1/2" x 16 mm	57	53	-	21	-	66	-	23	30
	R412PX232	3/8" x 16 mm	61	51	-	17	-	75	-	23	30
	R412PX233	1/2" x 16 mm	61	51	-	17	-	75	-	23	30
	R403PX224	1/2" x 18 mm (LEFT)	41	50	58	24	-	63	71	23	30
	R403PX234	1/2" x 18 mm (RIGHT)	41	50	58	24	-	63	71	23	30
	R415PX242	1/2" x 16 mm	53	45	-	36	-	95	-	23	30



Product specifications

R401PTG

Valve with thermostatic option and presetting, angled, chrome-plated, with iron pipe connection. Body in brass UNI EN 12165 CW617N. Worksite protection handwheel in PP-H. Monobloc command stem in stainless steel. Seal on command stem with O-Ring in EPDM. Temperature range 5÷110 °C. Max. working pressure 16 bar (10 bar with thermostatic head or thermo-electric actuator).

R402PTG

Valve with thermostatic option and presetting, straight, chrome-plated, with iron pipe connection. Body in brass UNI EN 12165 CW617N. Worksite protection handwheel in PP-H. Monobloc command stem in stainless steel. Seal on command stem with O-Ring in EPDM. Temperature range 5÷110 °C. Max. working pressure 16 bar (10 bar with thermostatic head or thermo-electric actuator).

R403PTG

Valve with thermostatic option and presetting, double angled, chrome-plated, with iron pipe connection or connection for adaptor for copper / plastic / multilayer pipe. Body in brass UNI EN 12165 CW617N. Worksite protection handwheel in PP-H. Monobloc command stem in stainless steel. Seal on command stem with O-Ring in EPDM. Temperature range 5÷110 °C. Max. working pressure 16 bar (10 bar with thermostatic head or thermo-electric actuator).

R411PTG

Valve with thermostatic option and presetting, angled, chrome-plated, with connection for adaptor for copper / plastic / multilayer pipe. Body in brass UNI EN 12165 CW617N. Worksite protection handwheel in PP-H. Monobloc command stem in stainless steel. Seal on command stem with O-Ring in EPDM. Temperature range 5÷110 °C. Max. working pressure 16 bar (10 bar with thermostatic head or thermo-electric actuator).

R412PTG

Valve with thermostatic option and presetting, straight, chrome-plated, with connection for adaptor for copper / plastic / multilayer pipe. Body in brass UNI EN 12165 CW617N. Worksite protection handwheel in PP-H. Monobloc command stem in stainless steel. Seal on command stem with O-Ring in EPDM. Temperature range 5÷110 °C. Max. working pressure 16 bar (10 bar with thermostatic head or thermo-electric actuator).

R415PTG

Valve with thermostatic option and presetting, reverse angled, chrome-plated, with connection for adaptor for copper / plastic / multilayer pipe. Body in brass UNI EN 12165 CW617N. Worksite protection handwheel in PP-H. Monobloc command stem in stainless steel. Seal on command stem with O-Ring in EPDM. Temperature range 5÷110 °C. Max. working pressure 16 bar (10 bar with thermostatic head or thermo-electric actuator).

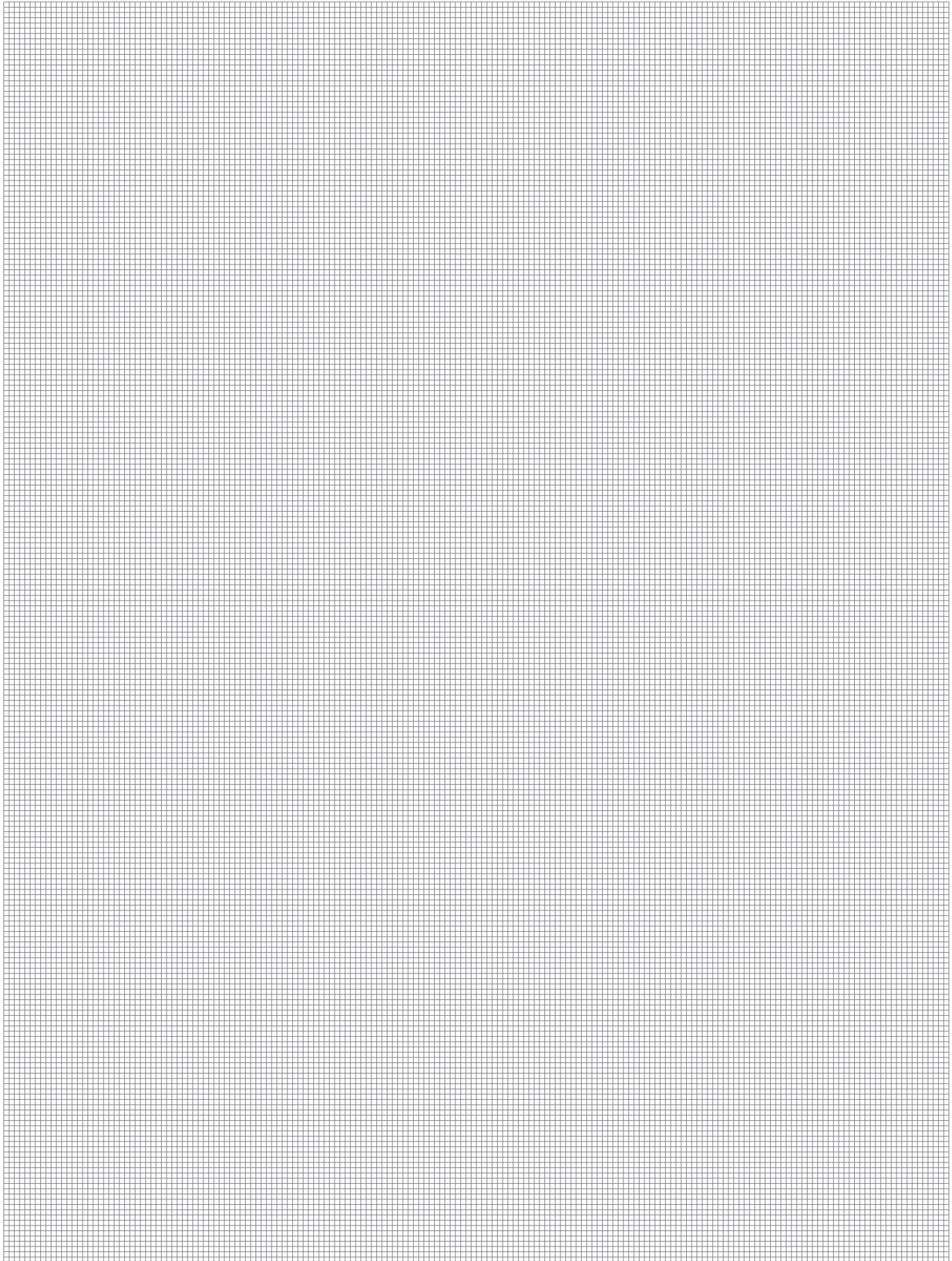

Additional information

For more information, go to www.giacomini.com or contact our technical assistance service: ☎ +39 0322 923372 📠 +39 0322 923255 ✉ consulenza.prodotti@giacomini.com
This document provides only general indications. Giacomini S.p.A. may change at any time, without notice and for technical or commercial reasons, the items included herewith.
The information included in this technical sheet do not exempt the user from strictly complying with the rules and good practice standards in force.
Giacomini S.p.A. Via per Alzo, 39 - 28017 San Maurizio d'Opaglio (NO) Italy