



**KF200**

**Description**

The KF200 control module is a Giacomlima component designed to be used with K482F, K482D or K483F digital environment thermometers: it is used in applications that use two-pipe fan coil terminal units or dehumidification terminal units in Giacomini systems for radiant floor or ceiling heating and/or cooling. The KF200 control module with K483F environment thermostat, via bus, can be used in combination with the KM203 control and supervision unit, the KD200/KD300 display and the KPM20 control unit.

The KF200 module must be installed directly on the fan coil unit of dehumidification unit box with self-threading screws.

The KF200 module, in combination with K482F and K483F digital environment thermostats, can control the water coil valve actuator and can also control the unit 3-speed fan. To control several fan coil units in parallel, the K482F and K483F digital environment thermostats must be combined with several KF200 power modules each one of which controlling a 3-speed fan and eventually the valve on the water coil.

The KF200 module, in combination with the K482D digital environment thermostat with humidistat function, can be used to activate a dehumidification unit.

**Main characteristics**

- Power supply 230V ±15 %
- Installation directly onto the fan coil or dehumidifier unit box
- 4 digital inputs for setting the digital thermostat controls.
- 1 powered digital output for the ON/OFF actuator control on the water coil valve
- 3 powered digital outputs for the control of a 3-speed fan
- Delayed action protection fuse (250V 3,1 A) for fan and fan coil actuator valve

**Connections**

The K482F or K483F digital environment thermostat can control several fan coils in parallel using one KF200 module for each fan coil: the KF200 modules must be electrically connected in parallel.

In installations where a two-way valve or 3-way deviator are used on the water coil, the NC series R473 (230V) electric actuator can be used.

**Connection 1 fan coil  
(with K482F or K483F environment thermostat)**

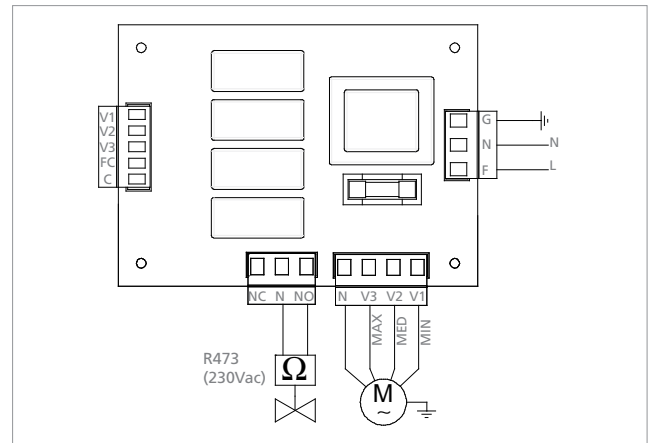

**Connection 2 fan coils in parallel  
(with K482F or K483F environment thermostat)**

A maximum of 4 KF200 control modules can be controlled in parallel by the same environment thermostat. One KF200 control module is already included with the K482F and K483F environment thermostats: to control a larger number of modules in parallel, refer to the KF200Y001 code.

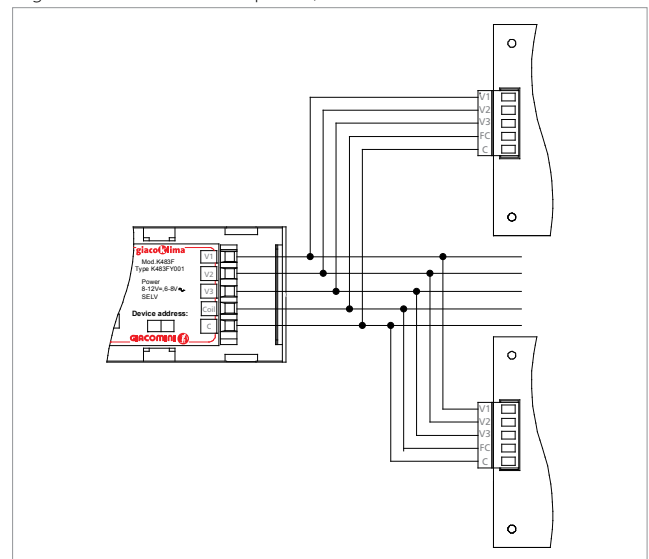

**Connection 1 fan dehumidifier  
(with K482D environment thermostat)**

The activator is powered only when the K482D thermostat is in SUMMER conduction mode. The contact is internally powered with a voltage of 230V~.

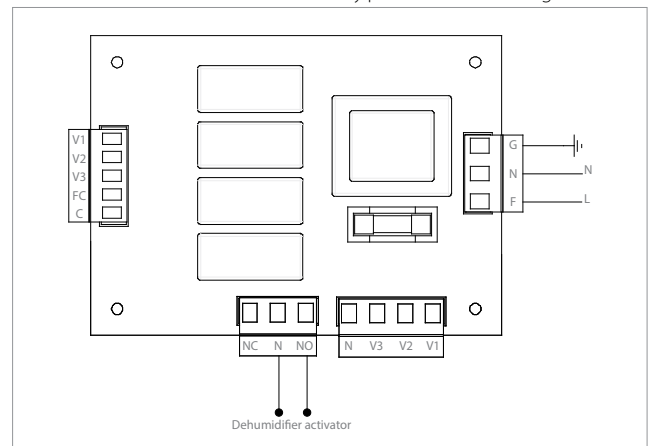



Terminal identifier	Function
NO	Contact terminal normally open – the contact closes when it becomes necessary to dehumidify (R.H. measured > R.H set)
C	Neutral connection terminal
NC	Contact terminal normally closed – the contact opens when it becomes necessary to dehumidify (R.H. measured > R.H set)



**Warning.**  
For connection to the 3-speed fan or to the dehumidifier, use double insulation cables. The protection of consumers, addressed in the KF200 information card, is ensured through the use of time delay fuse (250 V~, 3.1A). This protection allows for the control of one fan coil unit, using the R473 electric actuator for the water coil valve and fans with a maximum absorbed power of 200 VA.

**Terminal legend**

**Power supply**

Terminal identifier	Function
F	Phase 230V~
N	Neutral 230V~
G	Earth connection

**Digital thermostat inputs K482F, K482D or K483F**

Terminal identifier	Function
V1	Signal (output, open collector type)
V2	Signal (output, open collector type)
V3	Signal (output, open collector type)
FC	Signal (output, open collector type)
C	Common signal

**Outlets**

Terminal identifier	Function
NO	Contact normally open under 230 V~ current, for coil valve actuator control with K482F and K483F; for dehumidifier activation with K482D
N	Neutral 230 V~
NC	Contact normally closed under 230 V~ current, for coil valve actuator control with K482F and K483F; for dehumidifier activation with K482D
N	Neutral 230 V~
V3	Contact under 230 V~ current, fan coil control at speed 3 for K482F and K483F
V2	Contact under 230 V~ current, fan coil control at speed 2 for K482F and K483F
V1	Contact under 230 V~ current, fan coil control at speed 1 for K482F and K483F

**Installation**

Mount the KF200 module directly on the fan coil unit box, near the fan external cables.

- Carry out the electrical connection of the fan to the terminal board
- Carry out the electrical connection of the actuator (if present) of the water coil interceptor valve to the terminal board
- Carry out the electrical connections of the 230 V~ power supply to the terminal board
- Earth the box by connecting the metal case directly to the earth terminal, with the letter G on the terminal board
- Fix the KF200 module to the box using the dedicated slotted holes and the self-threading screws with a 3÷4 mm diameter.

**Warning.**  
The KF200 module **MUST NOT** be installed in an open, unprotected space; it must only be installed inside the fan coil or dehumidifier unit box. Ensure that the power supply is suspended while the connections are being carried out. Use double insulation cables for all connections. The installation of the device must only be carried out by qualified personnel.

**Dimensions**

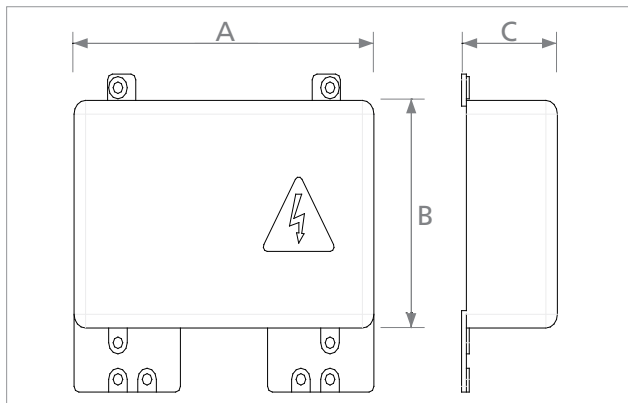

**Technical data**

FOR ALL VERSIONS	
Power supply voltage	230 V ±15 %
Current	I nominal 20 mA~
Time delay	fuse, 250 V~, 3,1 A
Digital inputs	4 opto-isolated, controlled by outputs of open collector type on the K482F, K482D or K483F digital thermostat
Digital outputs	- 1 S.P.D.T. type contact with power 230 V~ (internally powered), 10 A, cosΦ=1, for actuator control battery valve - 3 contacts with 230 V~ power (internally supplied), 10 A, cosΦ=1, for fan coil control at 3 speeds
EC compliance	Residential/industrial directive CE89/336/EEC, EN50081/1, EN50082/2
Protection degree	IP 20
Environmental operating conditions	0÷55 °C up to 90% R.H. (relative humidity).
Environmental conditions for storage	-34÷55 °C
Weight	0,3 Kg
Housing material	ABS/ self-extinguishing polycarbonate
Dimensions	157 x 100 x 50 mm (AxBxC)

**Product specifications**

**KF200**

Fan coil control module, for use with K482F, K482D or K483F digital thermostats. To be installed directly onto the fan coil unit. 230 V power supply. 4 digital inputs for setting the digital thermostat controls. 1 powered digital output for the ON/OFF actuator control on the water coil valve. 3 powered digital outputs for the control of a 3-speed fan. Delayed action protection fuse (250 V~ 3,1 A) for fan and actuator valve on the fan coil battery. To be used in combination with Giacoklima thermoregulation products. CE marked.

**Additional information**

For further information, visit the website [www.giacomini.com](http://www.giacomini.com) or contact the technical service: ☎ +39 0322 923372 📠 +39 0322 923255 ✉ [consulenza.prodotti@giacomini.com](mailto:consulenza.prodotti@giacomini.com)  
This information is intended as an example. Giacomini S.p.A. reserves the right to modify the contents - at any time and without prior warning - for technical or commercial reasons. The information in this technical sheet does not exempt the user from scrupulously observing the existing regulations and standards relating to good technical practices. Giacomini S.p.A. Via per Alzo, 39 - 28017 San Maurizio d'Opaglio (NO) Italy