



Description

To use heating energy only where and when it is actually needed, the most simple, cheap and reliable independent thermoregulation solution is to equip each radiator in the building with valves with thermostatic option and thermostatic heads.

Thermostatic heads serve to keep constant the ambient temperature of the room in which they are present, according to the set value. Where the radiator is shielded from the surrounding environment by curtains, drapes or radiator covers, a classic thermostatic head cannot be guaranteed to maintain the desired setting; in these cases, **R462** thermostatic heads with remote sensor can be used, or **R463** thermostatic heads with adjustment knob and remote sensor.

Versions and product codes

Series	Product code	Capillary pipe length [m]	Connection
R462	R462X002	2	Remote sensor, knob on valve
	R462X005	5	
R463	R463X002	2	Remote sensor and knob
	R463X005	5	

Accessories

- **R455AY001**: the R462 head can be rotated to the desired calibration position and then locked with the R445A protection device.

Technical data

- Can be installed on all valves with thermostatic option (except series H)
- Temperature range in combination with the valve bodies: 5-110 °C
- Max. working pressure in combination with the valve bodies: 10 bar
- Maximum differential pressure in the valve (TG and PTG series): 1,4 bar (3/8", 1/2"); 0,7 bar (3/4")
- Minimum head calibration: 8 °C in position 1
- Maximum head calibration: 32 °C in position 5

Hydraulic features

The data shown are obtained according to the specifications of the EN215 standard.

- **R462/R463 in combination with valves bodies 3/8" - 1/2"** (series R401TG, R402TG, R403TG, R415TG, R435TG, R421TG, R422TG, R401D, R402D)

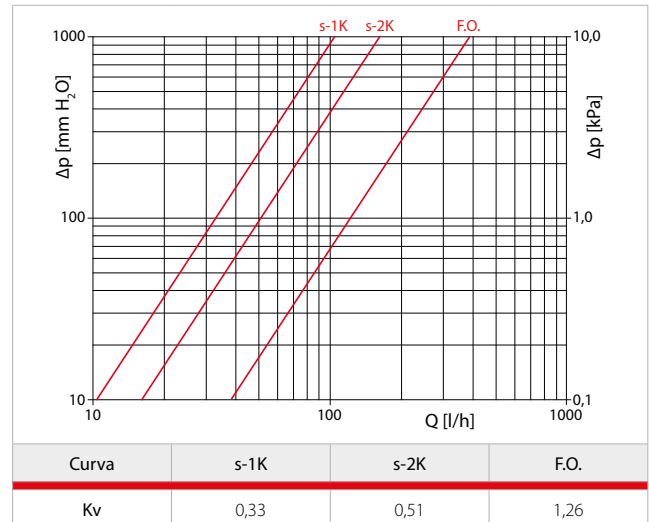

- **R462/R463 in combination with valves bodies 3/4"** (series R401D, R402D, R401F, R402F, R421F, R422F)

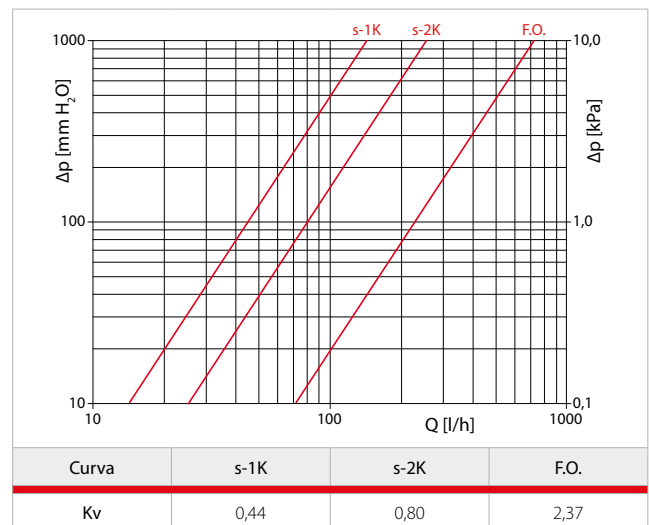

Operation

The variation in room temperature leads to a variation in the volume of liquid contained in the sensor inside the head. This volume change causes the movement of an internal mechanism and the resulting closure or opening of the valve, hence the modulated flow rate of water entering the heating element. When the temperature in the room is approaching the required value, the head gradually closes the valve, letting through just the minimum amount of water needed to keep the room temperature constant. This means guaranteed energy savings.

Installation

In order to ensure that the adjustments made are correct and durable, ensure that the capillary pipe, which serves to connect the two elements, is adequately protected.



Warning.

During installation, avoid repeated bending of the capillary pipe, which could lead to this becoming damaged irreparably, thus compromising the operation of the product. Ideally, installation should be carried out using a spiral sleeve (internal diameter > 25 mm), which should be traced in the first instance (avoiding excessive curvature), and into which the capillary pipe can then be slid.

R462 installation



1) Open the head completely by turning the knob to the fully open position .



2) Attach the thermostatic head to the valve, making sure that the slots provided on the attachment legs are lined up with the protruding pins on the valve.

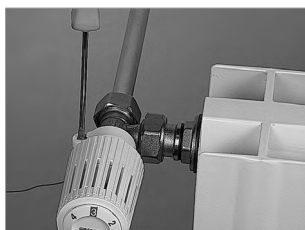

3) Position the clamp and tighten fully using a screwdriver.



4) The head is now fixed to the valve and can be moved to the required adjustment position by turning the knob.

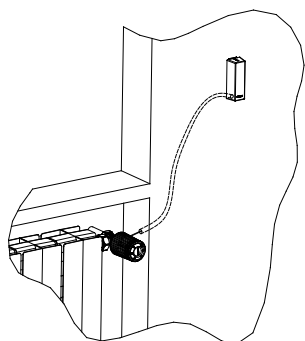

5) Install the sensor on a wall, at a height of around 1,5 m from the ground, using the installation kit included with the package.

R463 installation



1) In order to allow the capillary pipe to be inserted into the spiral sleeve, you will need to disassemble the cartridge, using a screwdriver as a lever through the side grooves until the perforated plate can be removed.

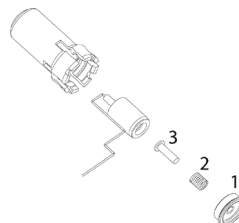

2) Pull out the end piece, making note of the sequence of the pieces: perforated plate(1), spring (2) and pin (3).

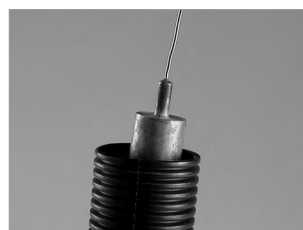

3) Pass the end of the capillary pipe through the spiral sleeve and at the exit, reassemble the cartridge by pressing the plate into its seat (as in the drawing above).



4) Attach the actuator to the valve, making sure that the slots provided on the attachment legs are lined up with the protruding pins on the valve.



5) Position the clamp and tighten fully using a screwdriver.

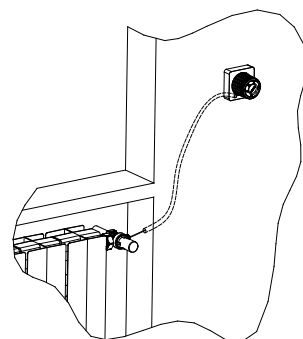

6) Install the adjustment knob at the desired distance, using the installation kit included with the package. The actuator is now fixed to the valve, and the adjustment knob can be moved to the required position.



Adjusting the temperature

The correct adjustment position for R462/R463 thermostatic heads is obtained by referring to the following table, which matches the numbering on the knob to the corresponding room temperatures.

Position	1	2	3	4	5
Mixing adjusted [°C]	8	15	20	25	32



NB:
The values shown in the table refer to the optimum conditions obtained in a climatic chamber. In the room itself, these values may be altered by factors such as the type of installation, the environmental conditions, the degree of insulation of the building, and certain characteristics of the heating element.



Warning.
To avoid excessive loads on the seal gasket of the thermostatic bonnet (with the resulting risk of jamming and locking) during the summer, it is a good idea to place the knob in the fully open position (5).

Locking the knob

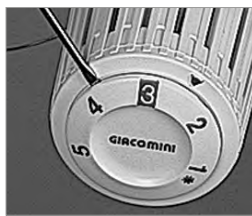

1) After turning the knob to the position in which it is to be locked, remove the numbered cover using a screwdriver.

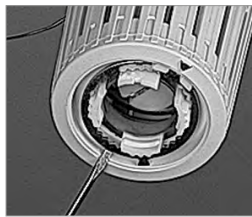

2) Remove the metal toothed ring from its seat by extracting it from the thermostatic head with the help of the screwdriver. During these operations, do not turn the knob on the thermostatic head or the calibration position will be lost.

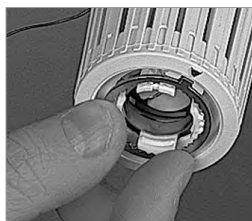

3) Insert the toothed ring in the head in such a way that the projecting tooth corresponds to the appropriate slot on the inside of the knob. When these steps have been completed, replace the cover, making sure it locks into position.

Limiting the aperture

Thermostatic heads R462 and R463 can be partially opened and closed. To **partially open** a thermostatic head, the knob must be turned to the maximum position required, before removing the numbered cover, extracting the metal ring nut and then reinserting it, making sure that the tooth is resting on the protruding part on the left of the knob. With the ring in this position, the thermostatic head can be closed by lowering the set temperature, but cannot be adjusted to higher temperatures. To prevent the **closure** of the head (in cases where users do not wish the ambient temperature to drop below a certain level), move it into the adjustment position required, remove the numbered cover, extract the metal ring and reinsert it in such a way that the tooth rests on the protruding part on the right of the knob. With the ring in this position, the head can be positioned beyond a minimum set value, but cannot be closed completely. After positioning of the ring inside the head is complete, the numbered cover can be replaced, taking care to place it back in its original position.

Dimensions

R462

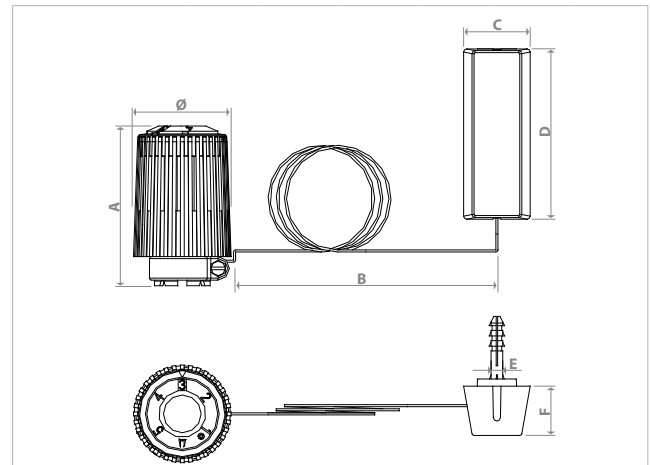

Product code	A [mm]	Ø [mm]	B [mm]	C [mm]	D [mm]	E [mm]	F [mm]
R462X002	88	47	2	32	83	6	24
R462X005	88	47	5	32	83	6	24

R463

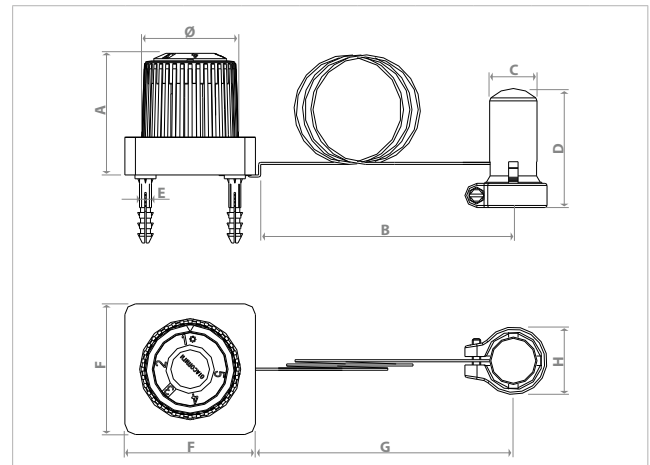

Product code	A [mm]	Ø [mm]	B [mm]	C [mm]	D [mm]	E [mm]	F [mm]	G [mm]	H [mm]
R463X002	64	47	2	22	57	6	62	2	32
R463X005	64	47	5	22	57	6	62	5	32

Product specifications

R462

Thermostatic head with remote liquid sensor. Adjustable on valve. Adjustment positions from 1 to 5, corresponding to a temperature range of 8÷32 °C. Possibility to block or achieve partial opening and/or closure. Can be adapted to all valves with thermostatic option (except series H). Capillary pipe length 2 or 5 m.

R463

Thermostatic head with liquid sensor and remote adjustment. Adjustment positions from 1 to 5, corresponding to a temperature range of 8÷32 °C. Possibility to block or achieve partial opening and/or closure. Can be adapted to all valves with thermostatic option (except series H). Capillary pipe length 2 or 5 m.

Additional information

For additional information please check the website: www.giacomini.com or contact the technical service: ☎ +39 0322 923372 6 📠 +39 0322 923255 ✉ consulenza.prodotti@giacomini.com
This pamphlet is merely for information purposes. Giacomini S.p.A. retains the right to make modifications for technical or commercial reasons, without prior notice, to the items described in this pamphlet. The information described in this technical pamphlet does not exempt the user from following carefully the existing regulations and norms on good workmanship.
Giacomini S.p.A. Via per Alzo, 39 - 28017 San Maurizio d'Opaglio (NO) Italy