



Description

The **R297** 3-way mixing valve enables to intercept and mix heat transfer fluids in heating and cooling hydronic systems.

The fluids are mixed through a rotating sector conferring a linear function to the valve while maintaining a low manoeuvring torque.

R297 valves can be used to both mix and divert the flow.

For optimal operation and control, R297 valves must be combined to a K275 or K275-1 actuator and may be controlled by KLIMAbus thermoregulation products.

Versions and product codes

| Product code | Connections | | Compatible actuators | |
|--------------|---------------------------|----------|--|--|
| | Type | Size | Actuator | Actuator installation kit |
| R297Y004 | Threaded Rp EN 10226-1 | 3/4" F | K275Y002 (series K275) K275Y013 (series K275-1) | KIT 0297 (included with the valve) |
| R297Y005 | | 1" F | | |
| R297Y006 | | 1 1/4" F | K275Y002 (series K275) K275Y013 (series K275-1) | |
| R297Y007 | | 1 1/2" F | | |
| R297Y008 | | 2" F | | |
| R297Y105 | Flanged EN 1092-2 | DN50 | K275Y002 (series K275) K275Y013 (series K275-1) | KIT P275 (to be ordered separately) |
| R297Y106 | | DN65 | | |
| R297Y108 | | DN80 | | |
| R297Y110 | | DN100 | | |
| R297Y112 | | DN125 | | |

Completion codes

- **K275Y002**: actuator with integrated constant temperature control
- **K275Y013**: actuator with 0...10 V control for use with KLIMAbus thermoregulation
- **P275Y001**: kit for installation of K275 and K275-1 actuators on R297 flanged valves
- **KLIMAbus thermoregulation**: KLIMAbus thermoregulation components (regulation module, thermostats, room probes, etc...)

Main characteristics

R297 3-way valves include a special sector rotor.

The special shape of this rotor enables these valves to perform an **equal-percentage regulation** (more details below).

In addition, the sector rotor can rotate by 360° so that R297 valves can be used both for **mixing and diverting**.

Last but not least, the rotor system of low-friction coefficient seals ensures **low manoeuvring torques** during operation.



R297 THREADED

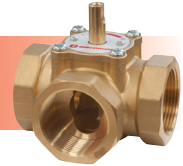

Technical data

- Fluids: water, glycol-based solutions (max. 50 %)
- Temperature range: 5÷110 °C
- Max. working pressure: 10 bar
- Max. differential pressure: 1 bar
- Rotation angle: 90° from initial position, in both directions (clockwise and anticlockwise)
- Kv/Kv_{min} setting range: 100
- Leakage: max. 0,1 % Kv with ΔP = 1 bar

Kv and weight

| Product code | Connections | Kv | Weight [kg] |
|--------------|-------------|----|-------------|
| R297Y004 | 3/4" F | 7 | 1,1 |
| R297Y005 | 1" F | 11 | 1,2 |
| R297Y006 | 1 1/4" F | 15 | 1,5 |
| R297Y007 | 1 1/2" F | 25 | 1,6 |
| R297Y008 | 2" F | 40 | 2,3 |

Materials

- Valve body: CW617N brass
- Rotating sector: CW617N brass
- Anti-friction ring: PTFE
- Gaskets: EPDM, FPM
- Covering plate: aluminum

Flow diagram

Equal-percentage valve: equal variations of the stroke absolute value always correspond to the same % variation of the efflux coefficient (example: if the valve opens by 10 %, the Kv will vary by 10 %).

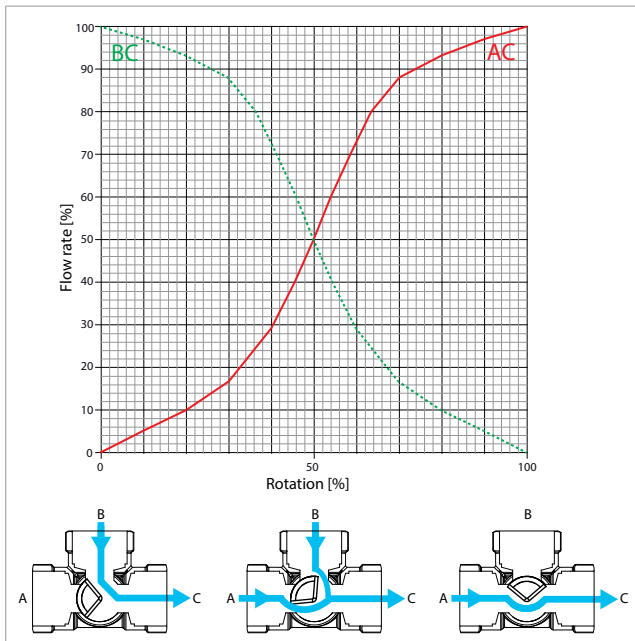

Maintenance

R297 threaded valves do not require any specific maintenance. We however recommend to verify proper operation of the valve and actuator once a year.

Operation

Mixing mode

R297 threaded valves may include a K275Y002 or K275Y013 actuator and work as a mixing valve.

The valve rotor, controlled by the actuator, can move by 90° in both directions (clockwise and anticlockwise) to mix the fluid from the boiler room (A) with the fluid from the heating/cooling system return circuit (B) and guarantee a delivery water temperature (AB) complying with the project requirements.

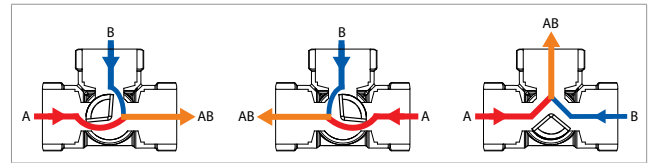

Diverting mode

R297 threaded valves may include a K275Y013 actuator and work as a diverting valve.



Note.

The valves cannot be used in diverting mode when installing the K275Y002 actuator.

The valve rotor, controlled by the actuator, can move by 90° in both directions (clockwise and anticlockwise) to divert the fluid from a valve inlet (A) to one of the two available outlets (B or C) based on the system requirements.

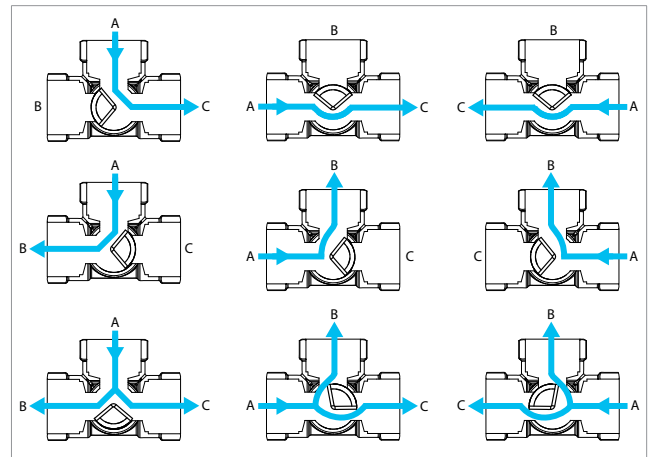

Installation

Allowed installation positions

R297 threaded valves may be installed vertically with the actuator on the left or right side or horizontally with the actuator on top. Horizontal installation with the actuator pointing downward is not allowed.

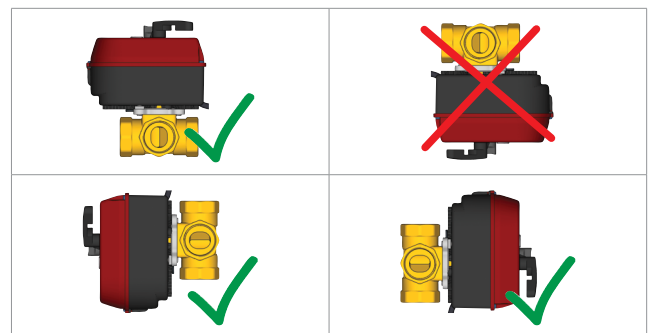

R297 3/4" - 1" - 1 1/4" THREADED VALVES

Before installing the actuator on the valve, fit its stem manually based on the desired mode (mixing valve or diverting valve).

The incision (A) on the valve stem always shows the current position of the rotor (B).

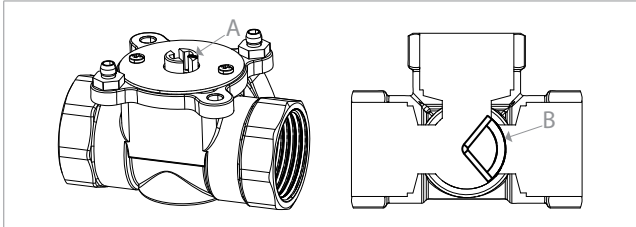

The valve rotor can turn by 90° in both directions (clockwise and anticlockwise); therefore, based on the initial point setting, it can move within a 180° range.

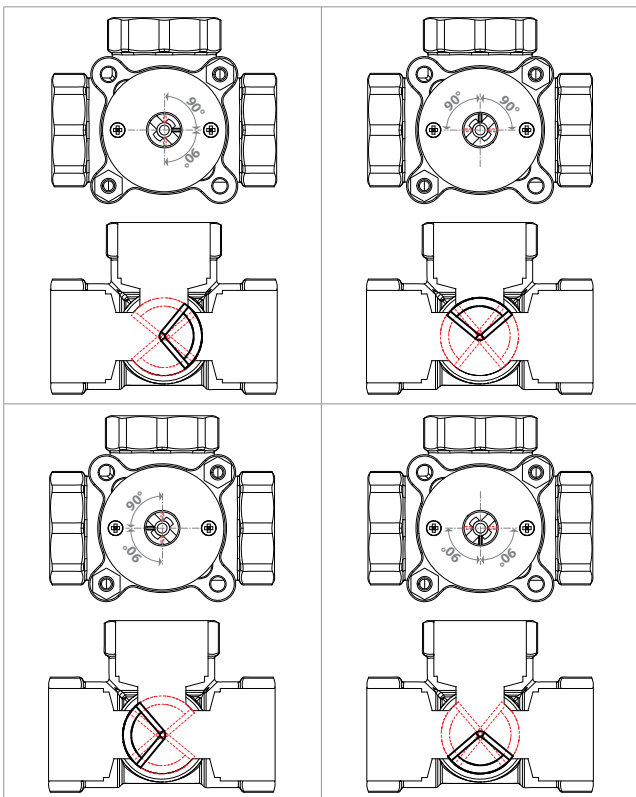

Set the correct operation values of the actuator (rotation direction, control signal, etc...) based on the desired rotor rotation, by using the internal DIP Switches



Note.
Refer to valve and actuator instructions to install the actuators and for proper setting of DIP Switches.

The face of the metal plate on the upper side of the valve can be inverted based on the rotation direction set on the actuator through the DIP Switches so as to show the proper opening range.

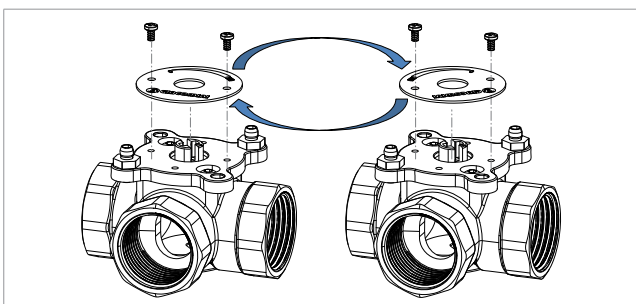

R297 1 1/2" - 2" THREADED VALVES

Before installing the actuator on the valve, fit its stem manually based on the desired mode (mixing valve or diverting valve).

The milling (A) on the valve stem always shows the current position of the rotor (B).

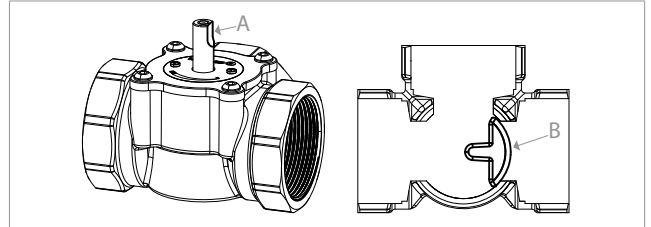

The valve rotor can turn by 90° in both directions (clockwise and anticlockwise); therefore, based on the initial point setting, it can move within a 180° range.

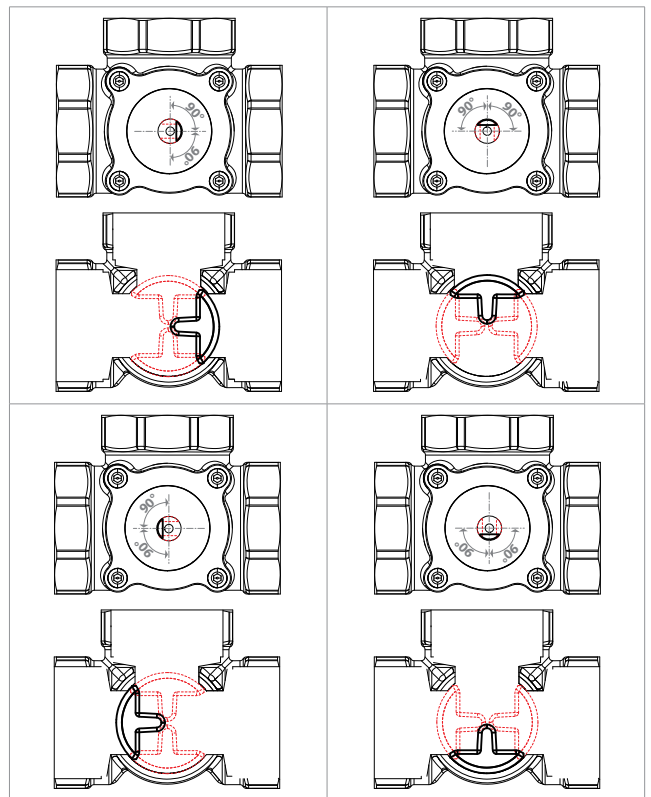

Set the correct operation values of the actuator (rotation direction, control signal, etc...) based on the desired rotor rotation, by using the internal DIP Switches



Note.
Refer to valve and actuator instructions to install the actuators and for proper setting of DIP Switches.

The face of the metal plate on the upper side of the valve can be inverted based on the rotation direction set on the actuator through the DIP Switches so as to show the proper opening range.

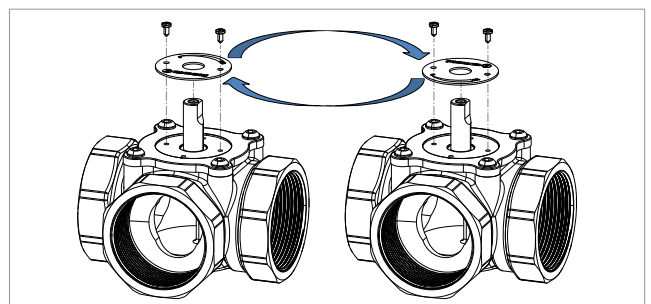



R297 FLANGED



Technical data

- Fluids: water, glycol-based solutions (max. 50 %)
- Temperature range: 5÷110 °C
- Max. working pressure: 6 bar
- Rotation angle: 90° from initial position in both directions (clockwise and anticlockwise)
- Kv/Kv_{min} setting range: 100
- Leakage: based on flow %, max. 1,5 %

Kv and weight

| Product code | Connections | Kv | Weight [kg] |
|--------------|-------------|-----|-------------|
| R297Y105 | DN50 | 60 | 9,1 |
| R297Y106 | DN65 | 90 | 10 |
| R297Y108 | DN80 | 150 | 16,2 |
| R297Y110 | DN100 | 225 | 21 |
| R297Y112 | DN125 | 280 | 27 |

Materials

- Body valve: EN-JL 1030 cast iron
- Rotating sector: CW614N brass and stainless steel
- Bush: CW602N brass
- Gaskets: EPDM
- Covering plate: cast iron

Flow diagram

Equal-percentage valve: equal variations of the stroke absolute value always correspond to the same % variation of the efflux coefficient (example: if the valve opens by 10 %, the Kv will vary by 10 %).

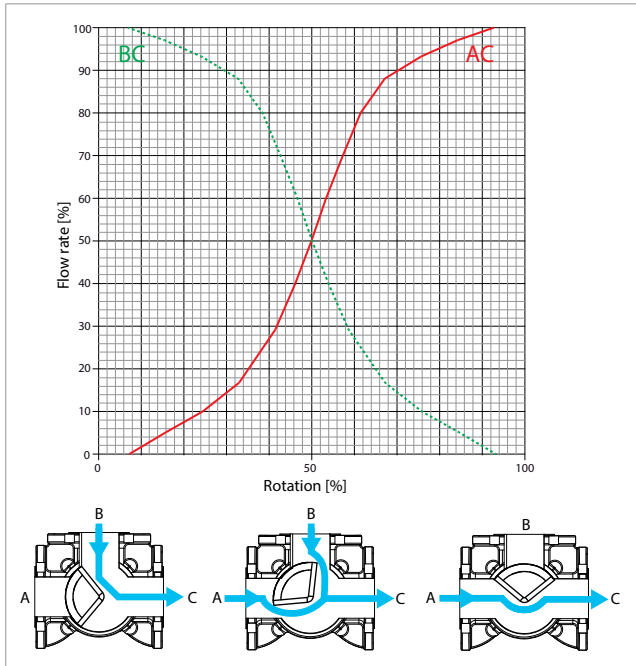

Maintenance

R297 flanged valves do not require any specific maintenance. We however recommend to verify proper operation of the valve and actuator once a year.

Operation

Mixing mode

R297 flanged valves may include a K275Y002 or K275Y013 actuator and work as a mixing valve.

The valve rotor, controlled by the actuator, can move by 90° in both directions (clockwise and anticlockwise) to mix the fluid from the boiler room (A) with the fluid from the heating/cooling system return circuit (B) and guarantee a delivery water temperature (AB) complying with the project requirements.

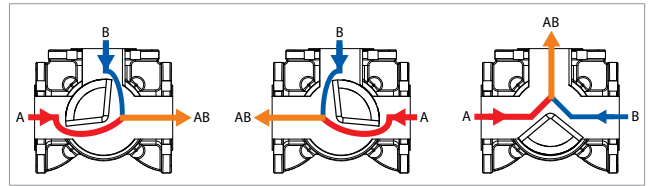

Diverting mode

R297 flanged valves may include a K275Y013 actuator and work as a diverting valve.



Note.

The valves cannot be used in diverting mode when installing the K275Y002 actuator.

The valve rotor, controlled by the actuator, can move by 90° in both directions (clockwise and anticlockwise) to divert the fluid from a valve inlet (A) to one of the two available outlets (B or C) based on the system requirements.

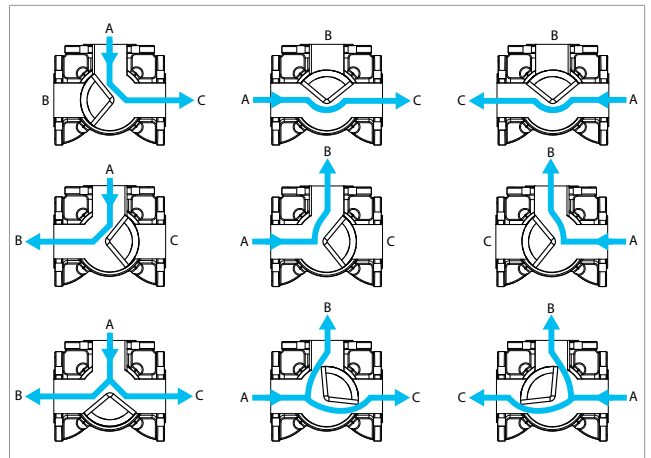

Installation

Allowed installation positions

R297 flanged valves may be installed vertically with the actuator on the left or right side or horizontally with the actuator on top. Horizontal installation with the actuator pointing downward is not allowed.

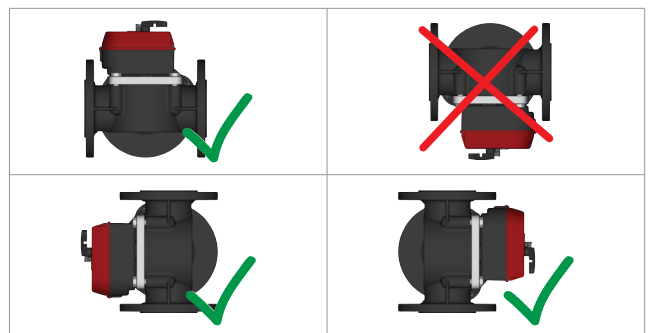

R297 FLANGED VALVES

Before installing the actuator on the valve, fit its stem manually based on the desired mode (mixing valve or diverting valve).

The milling (A) on the valve stem always shows the current position of the rotor (B).

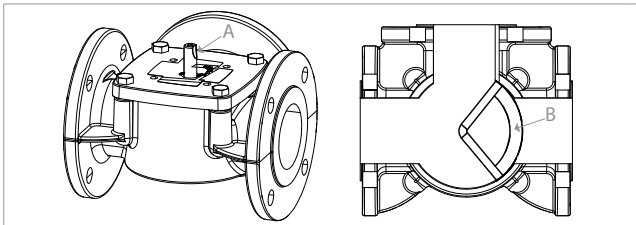

The valve rotor can turn by 90° in both directions (clockwise and anticlockwise); therefore, based on the starting point setting, it can move within a 180° range.

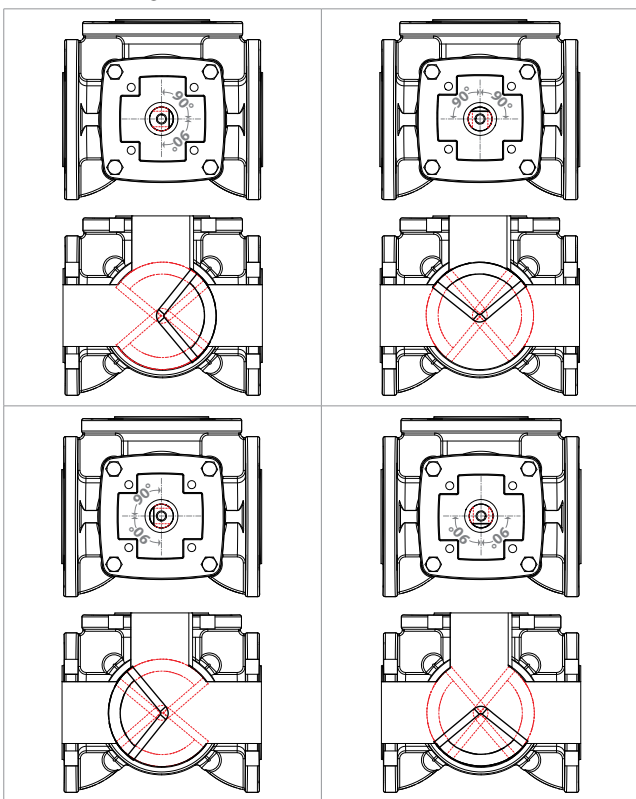

Set the correct operation values of the actuator (rotation direction, control signal, etc...) based on the desired rotor rotation, by using the internal DIP Switches



Note.
Refer to valve and actuator instructions to install the actuators and for proper setting of DIP Switches

The face of the metal plate on the upper side of the valve can be inverted based on the rotation direction set on the actuator through the DIP Switches so as to show the proper opening range.

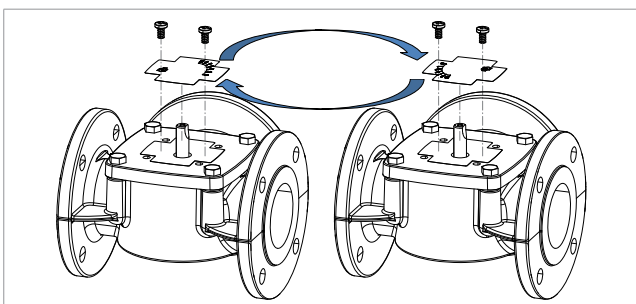

DIMENSIONS

R297 3/4" - 1" - 1 1/4" threaded valves

| Product code | Connections A | B [mm] | C [mm] | D [mm] | E [mm] | F [mm] | G [mm] | H [mm] | Valves + K275 or K275-1 actuators | | |
|--------------|---------------|--------|--------|--------|--------|--------|--------|--------|-----------------------------------|--------|--------|
| | | | | | | | | | I [mm] | L [mm] | M [mm] |
| R297Y004 | 3/4"F | 36 | 72 | 27 | 36 | 63 | 19 | 53 | 78 | 125 | 145 |
| R297Y005 | 1"F | 41 | 82 | 27 | 41 | 68 | 21 | 55 | 82 | 125 | 147 |
| R297Y006 | 1 1/4"F | 47 | 94 | 27 | 47 | 74 | 25 | 62 | 94 | 125 | 154 |

R297 1 1/2" - 2" threaded valves

| Product code | Connections A | B [mm] | C [mm] | D [mm] | E [mm] | F [mm] | G [mm] | H [mm] | Valves + K275 or K275-1 actuators | | |
|--------------|---------------|--------|--------|--------|--------|--------|--------|--------|-----------------------------------|--------|--------|
| | | | | | | | | | I [mm] | L [mm] | M [mm] |
| R297Y007 | 1 1/2"F | 53 | 106 | 30 | 53 | 83 | 30 | 96 | 106 | 125 | 179 |
| R297Y008 | 2"F | 60 | 120 | 35 | 60 | 95 | 35 | 103 | 120 | 125 | 186 |

R297 flanged valves

| Product code | Connections A | B [mm] | C [mm] | D [mm] | E [mm] | F [mm] | G [mm] | H [mm] | I [mm] | Ø [mm] | Valves + K275 or K275-1 actuators | | |
|--------------|---------------|--------|--------|--------|--------|--------|--------|--------|--------|-----------|-----------------------------------|--------|--------|
| | | | | | | | | | | | L [mm] | M [mm] | N [mm] |
| R297Y105 | DN50 | 97,5 | 195 | 70 | 98 | 168 | 70 | 140 | 78 | N°4 x Ø15 | 195 | 168 | 225 |
| R297Y106 | DN65 | 100 | 200 | 80 | 100 | 180 | 80 | 160 | 92 | N°4 x Ø15 | 200 | 180 | 245 |
| R297Y108 | DN80 | 120 | 240 | 95 | 120 | 215 | 95 | 190 | 107 | N°4 x Ø18 | 240 | 215 | 265 |
| R297Y110 | DN100 | 132,5 | 265 | 105 | 133 | 238 | 105 | 210 | 121 | N°4 x Ø18 | 265 | 238 | 290 |
| R297Y112 | DN125 | 150 | 300 | 120 | 150 | 270 | 120 | 240 | 77 | N°8 x Ø18 | 300 | 270 | 300 |

EXAMPLE OF APPLICATION DIAGRAM

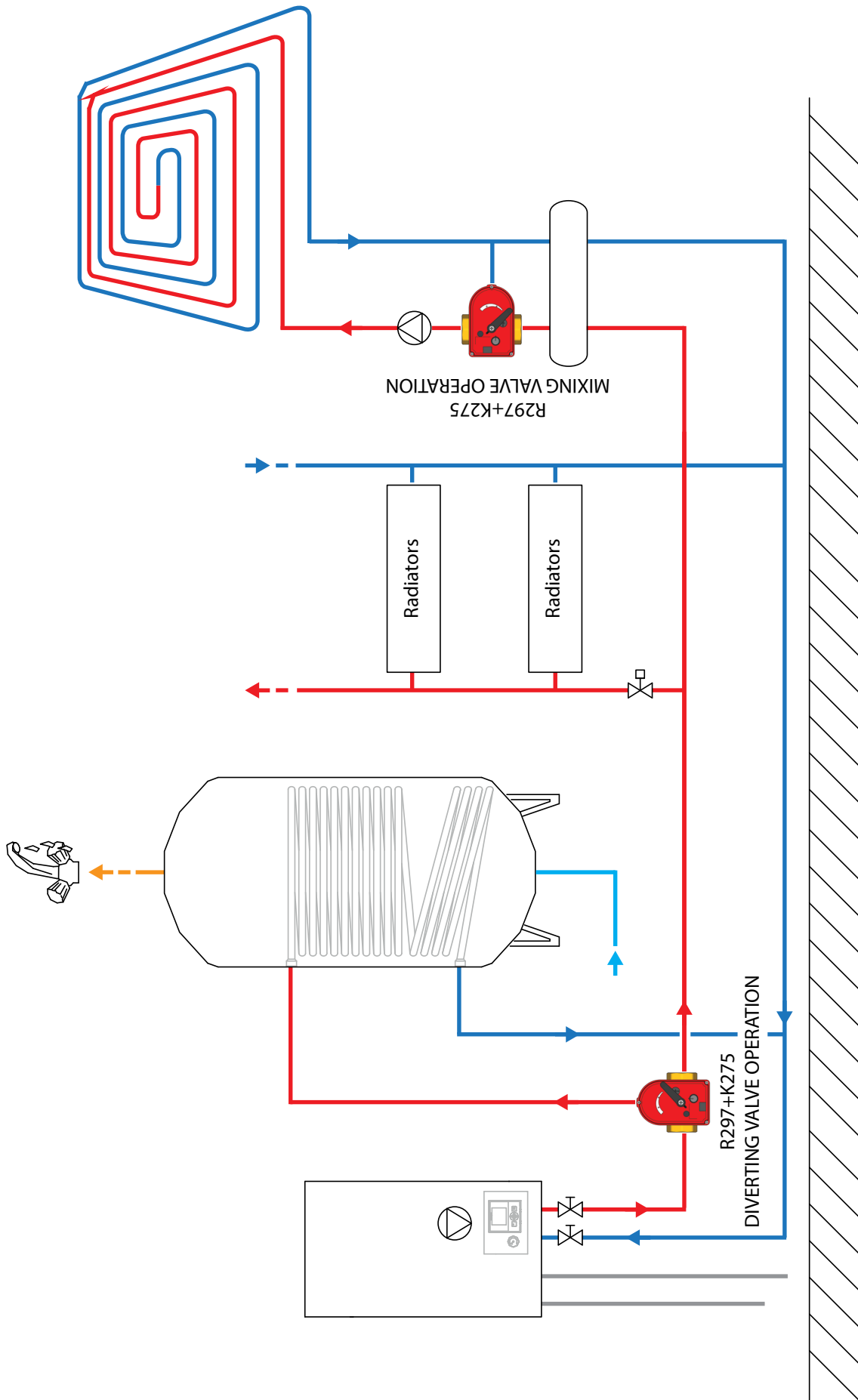



PRODUCT SPECIFICATIONS

R297Y004

3-way sector mixing valve with Rp 3/4" F threaded connections EN 10226-1. Body, bonnet and rotating sector UNI EN 12165 CW617N brass; PTFE anti-friction ring; EPDM or FPM gaskets; aluminum covering plate. Fluids: water, glycol-based solutions (max. 50 %). Temperature range: 5÷110 °C. Max. working pressure: 10 bar. Rotation angle: 90° from initial position, in both directions (clockwise and anti-clockwise). Weight: 1,1 kg. Motorizable with installation of K275 or K275-1 actuator.

R297Y005

3-way sector mixing valve with Rp 1" F threaded connections EN 10226-1. Body, bonnet and rotating sector UNI EN 12165 CW617N brass; PTFE anti-friction ring; EPDM or FPM gaskets; aluminum covering plate. Fluids: water, glycol-based solutions (max. 50 %). Temperature range: 5÷110 °C. Max. working pressure: 10 bar. Rotation angle: 90° from initial position, in both directions (clockwise and anti-clockwise). Weight: 1,2 kg. Motorizable with installation of K275 or K275-1 actuator.

R297Y006

3-way sector mixing valve with Rp 1 1/4" F threaded connections EN 10226-1. Body, bonnet and rotating sector UNI EN 12165 CW617N brass; PTFE anti-friction ring; EPDM or FPM gaskets; aluminum covering plate. Fluids: water, glycol-based solutions (max. 50 %). Temperature range: 5÷110 °C. Max. working pressure: 10 bar. Rotation angle: 90° from initial position, in both directions (clockwise and anti-clockwise). Weight: 1,5 kg. Motorizable with installation of K275 or K275-1 actuator.

R297Y007

3-way sector mixing valve with Rp 1 1/2" F threaded connections EN 10226-1. Body, bonnet and rotating sector UNI EN 12165 CW617N brass; PTFE anti-friction ring; EPDM or FPM gaskets; aluminum covering plate. Fluids: water, glycol-based solutions (max. 50 %). Temperature range: 5÷110 °C. Max. working pressure: 10 bar. Rotation angle: 90° from initial position, in both directions (clockwise and anti-clockwise). Weight: 1,6 kg. Motorizable with installation of K275 or K275-1 actuator.

R297Y008

3-way sector mixing valve with Rp 2" F threaded connections EN 10226-1. Body, bonnet and rotating sector UNI EN 12165 CW617N brass; PTFE anti-friction ring; EPDM or FPM gaskets; aluminum covering plate. Fluids: water, glycol-based solutions (max. 50 %). Temperature range: 5÷110 °C. Max. working pressure: 10 bar. Rotation angle: 90° from initial position, in both directions (clockwise and anti-clockwise). Weight: 2,3 kg. Motorizable with installation of K275 or K275-1 actuator.

R297Y105

3-way sector mixing valve with flanged connections EN 1092-2, DN50. Cast iron body and covering plate; rotating sector UNI EN 12165 CW617N brass and stainless steel; bush CW602N brass; EPDM gaskets. Fluids: water, glycol-based solutions (max. 50 %). Temperature range: 5÷110 °C. Max. working pressure: 6 bar. Rotation angle: 90° from initial position, in both directions (clockwise and anti-clockwise). Weight: 9,1 kg. Motorizable with installation of K275 or K275-1 actuator and P275 kit.

R297Y106

3-way sector mixing valve with flanged connections EN 1092-2, DN65. Cast iron body and covering plate; rotating sector UNI EN 12165 CW617N brass and stainless steel; bush CW602N brass; EPDM gaskets. Fluids: water, glycol-based solutions (max. 50 %). Temperature range: 5÷110 °C. Max. working pressure: 6 bar. Rotation angle: 90° from initial position, in both directions (clockwise and anti-clockwise). Weight: 10 kg. Motorizable with installation of K275 or K275-1 actuator and P275 kit.

R297Y108

3-way sector mixing valve with flanged connections EN 1092-2, DN80. Cast iron body and covering plate; rotating sector UNI EN 12165 CW617N brass and stainless steel; bush CW602N brass; EPDM gaskets. Fluids: water, glycol-based solutions (max. 50 %). Temperature range: 5÷110 °C. Max. working pressure: 6 bar. Rotation angle: 90° from initial position, in both directions (clockwise and anti-clockwise). Weight: 16,2 kg. Motorizable with installation of K275 or K275-1 actuator and P275 kit.

R297Y110

3-way sector mixing valve with flanged connections EN 1092-2, DN100. Cast iron body and covering plate; rotating sector UNI EN 12165 CW617N brass and stainless steel; bush CW602N brass; EPDM gaskets. Fluids: water, glycol-based solutions (max. 50 %). Temperature range: 5÷110 °C. Max. working pressure: 6 bar. Rotation angle: 90° from initial position, in both directions (clockwise and anti-clockwise). Weight: 21 kg. Motorizable with installation of K275 or K275-1 actuator and P275 kit.

R297Y112

3-way sector mixing valve with flanged connections EN 1092-2, DN125. Cast iron body and covering plate; rotating sector UNI EN 12165 CW617N brass and stainless steel; bush CW602N brass; EPDM gaskets. Fluids: water, glycol-based solutions (max. 50 %). Temperature range: 5÷110 °C. Max. working pressure: 6 bar. Rotation angle: 90° from initial position, in both directions (clockwise and anti-clockwise). Weight: 27 kg. Motorizable with installation of K275 or K275-1 actuator and P275 kit.

Additional information

For additional information please check the website www.giacomini.com or contact the technical service: ☎ +39 0322 923372 📠 +39 0322 923255 ✉ consulenza.prodotti@giacomini.com
This pamphlet is merely for information purposes. Giacomini S.p.A. retains the right to make modifications for technical or commercial reasons, without prior notice, to the items described in this pamphlet. The information described in this technical pamphlet does not exempt the user from following carefully the existing regulations and norms on good workmanship.
Giacomini S.p.A. Via per Alzo, 39 - 28017 San Maurizio d'Opaglio (NO) Italy